

Commando

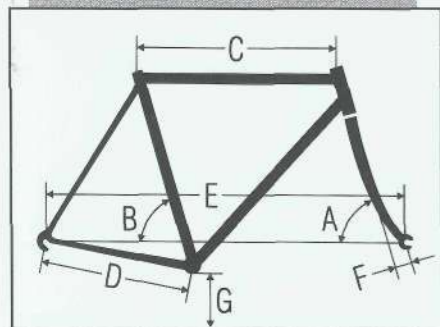

FRAME SIZE	A	B	C	D	E	F	G
17/24	69°	73°	20	17.0	40.2	2.0	11.5
17/26	69°	73°	21.5	17.4	41.8	2.0	11.5
18	69°	73°	22	17.4	42.3	2.0	11.5
19	69°	73°	22	17.4	42.3	2.0	11.5
20	69°	73°	22.5	17.4	42.8	2.0	11.5
21.5	69°	73°	23	17.4	43.3	2.0	11.5
23	69°	73°	23.5	17.4	43.8	2.0	11.5
24	69°	73°	24	17.4	44.3	2.0	11.5
25	69°	73°	24.5	17.4	44.8	2.0	11.5

The COMMANDO is built with adventure in mind. It's a get-away machine with every conceivable braze-on, including water bottles, racks, low riders, fenders and portage carry strap. This off-road expedition vehicle is topped off with a camouflage paint job and black anodized SHIMANO and SUNTOUR component group, creating a wilderness feeling that's irresistible. The COMMANDO will inspire you to challenge the outdoors in your neighborhood or around the world. Fully hand fillet brazed by TOM RITCHEY using RITCHEY 4130 double-butted chromoly tubing, it's another example of a RITCHEY that defines the state of the art in mountain bikes. ●



RITCHEY COMMANDO™/SPECIFICATIONS

FRAME	Designed and Built by TOM RITCHEY, using RITCHEY Double-Butted 4130 Chrome Molybdenum Frame Tubing.
FORK	Designed and Built by TOM RITCHEY, using RITCHEY 4130 Chrome Molybdenum UNIFORK Blades.
BRAZE-ONS	Double Water Bottle Bosses, Rear Rack, Low Rider, Front and Rear Fender Bosses. Special Slotted Cable Stops and Guides. Front and Rear Cantilever Bosses. Dropout Eyelets Front and Rear.
HANDLEBAR	RITCHEY Design Model I Black Chromoly TWINSTRUT.
SADDLE	SPECIALIZED Lambda.
SEATPOST	STRONG 260mm.
SEATPOST BOLT	SUNTOUR QR-170.
HEADSET	SHIMANO 600 EX.
BOTTOM BRACKET	SHIMANO 600 EX Sealed with Chromoly Axle.
CRANKSET	SHIMANO 600 EX Triple. Black Arms and Chainrings. 48/38/28. Crank Length matched to Frame Size.
PEDALS	SUNTOUR XC-2 "Bearpaw".
REAR DERAILLEUR	SHIMANO DEORE XT.
FRONT DERAILLEUR	SHIMANO DEORE XT.
SHIFT LEVERS	SHIMANO DEORE XT Black.
BRAKES	SHIMANO DEORE XT Black Cantilevers.
BRAKE LEVERS	MAGURA "Shorty" Black.
HUBS	SUNTOUR XC Sealed.
RIMS	ARAYA RM 25 Black.
SPOKES	WHEELSMITH 14G Stainless.
TIRES	RITCHEY QUAD 1.9.
FREEWHEEL	SHIMANO 600 EX 13-28 6 Speed.
CHAIN	SHIMANO UNIGLIDE.
WEIGHT	28 lbs.
SIZES	17/24", 17/26", 18", 19", 20", 21.5", 23". OPTION: 24", 25". (Center to Top)
COLOR	CAMOUFLAGE.
ACCESSORY	JUNGLE DESIGNS Carry Strap.

Annapurna

There is hand built and then there is the ANNAPURNA. A limited edition, exquisitely finished frameset built with RITCHEY 4130 double butted chromoly tubing, the ANNAPURNA is the ultimate creation of a one in a thousand master of the torch. Bicycling Magazine called it "one of the 2 or 3 prettiest at any price ... there is no disputing the superiority of the ANNAPURNA's framework or finish". Artfully sculpted head and down tube reinforcing sleeves highlight the beauty and elegance of the ANNAPURNA. Most DUPONT IMRON colors are available to satisfy your personal taste. A carefully selected component group with SHIMANO, SUNTOUR, and MAGURA components finish a bicycle that is joy to own and a pleasure to ride. ●



FRAME SIZE	A	B	C	D	E	F	G
19	69°	73°	22	17.4	42.3	2.0	11.5
20	69°	73°	22.5	17.4	42.8	2.0	11.5
21	69°	73°	23	17.4	43.3	2.0	11.5
22	69°	73°	23	17.4	43.3	2.0	11.5
23	69°	73°	23.5	17.4	44.3	2.0	11.5
24	69°	73°	24	17.4	44.8	2.0	11.5
25	69°	73°	24.5	17.4	44.8	2.0	11.5

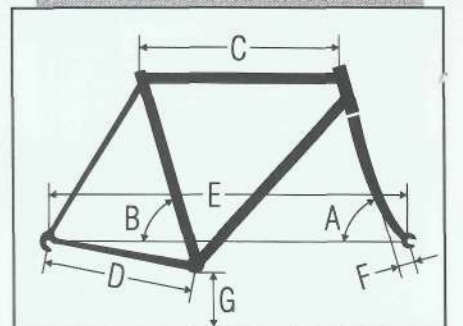

RITCHEY ANNAPURNA™/SPECIFICATIONS

FRAME	Designed and Built by TOM RITCHEY, using RITCHEY Double-Butted Chrome Molybdenum Frame Tubing.
FORK	Designed and Built by TOM RITCHEY, using RITCHEY 4130 Chrome Molybdenum UNIFORK Blades.
BRAZE-ONS	Double Water Bottle Bosses, Special Slotted Cable Stops and Guides. Cantilever Bosses Front and Rear. Dropout Eyelets Front and Rear. Additional Braze-On Options Available.
HANDLEBAR	Designed and Built by TOM RITCHEY, Model III Chromoly TWINSTRUT with RITCHEY Double Expander.
SADDLE	SPECIALIZED Lambda S.
SEATPOST	SUNTOUR XC 300mm.
SEATPOST BOLT	SUNTOUR QR-170.
HEADSET	SHIMANO 600 EX.
BOTTOM BRACKET	SHIMANO 600 EX Sealed with Chromoly Axle.
CRANKSET	SHIMANO 600 EX Triple. 48/38/28. Crank Length matched to Frame Size.
PEDALS	SUNTOUR XC-2 "Bearpaw".
REAR DERAILLEUR	SHIMANO DEORE XT.
FRONT DERAILLEUR	SHIMANO DEORE XT.
SHIFT LEVERS	SHIMANO DEORE XT.
BRAKES	SHIMANO DEORE XT Cantilevers.
BRAKE LEVERS	MAGURA "Shorty" with Covers.
HUBS	SHIMANO NEW DURA-ACE Low Flange Quick Release Cassette 6 Speed.
RIMS	ARAYA RM 20.
SPOKES	WHEELSMITH 14G Stainless.
TIRES	RITCHEY QUAD 1.9.
CHAIN	SHIMANO UNIGLIDE.
WEIGHT	27 lbs.
SIZES	19", 20", 21", 22", 23", 24", 25". (Center to Top)
COLOR	Most DUPONT IMRON Colors.

